

VIEW THROUGH LID

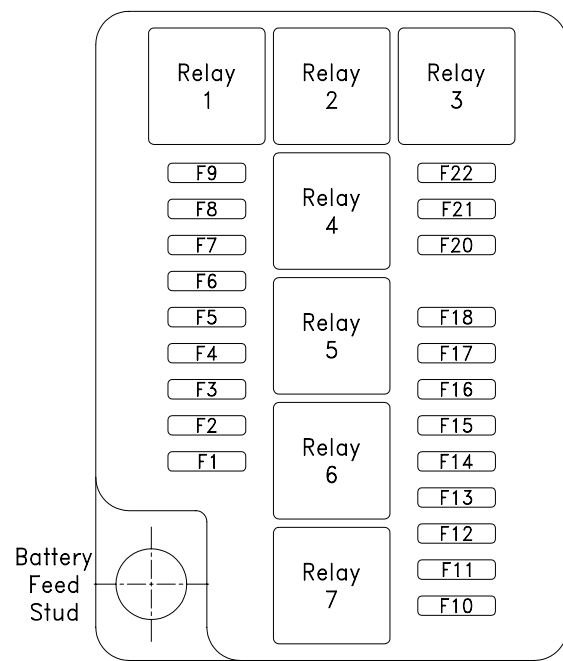

FUSEBOX CONNECTOR	CONNECTOR COLOUR	CIRCUIT C NUMBER
A	WHITE	C2010
B	BLACK	C2011
C	GREEN	C2012
D	BLUE	C2013



DRAWN BY AP  
DATE 13-07-07

TITLE REAR FUSEBOX  
SUB-SYSTEM TITLE 4G43-14A073-AJ

PROJECT VH105/135 CPSC 00.06.51 AML DRG No.  
BUILD IB REV LEVEL 1 8G43-14T400-AA